

Airflow Sensors Microbridge Mass Airflow/Unamplified

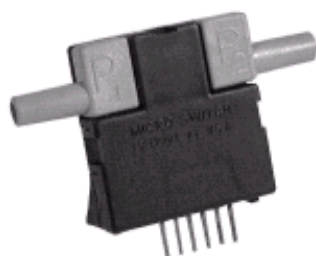

FEATURES

- Bidirectional sensing capability
- Actual mass air flow sensing
- Low differential pressure sensing

The AWM2000 Series microbridge mass airflow sensor is a passive device comprised of two Wheatstone bridges. The heater control circuit in Figure 1 is required for operation per specifications. The sensing bridge supply circuit in Figure 2 is also required for operation per specifications. These two circuits are not on board the package and must be supplied in the application. The differential amplifier in Figure 3 is a useful interface for the sensing bridge. It can be used to introduce the gain and to introduce voltage offsets to the sensor output as referenced in Equation 1.

Note: For applications sensing hydrogen or helium, see Application Note 3, page 131.

Figure 1
Heater Control Circuit

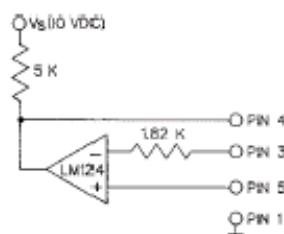

Figure 2
Sensing Bridge Supply Circuit

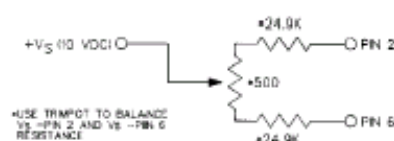
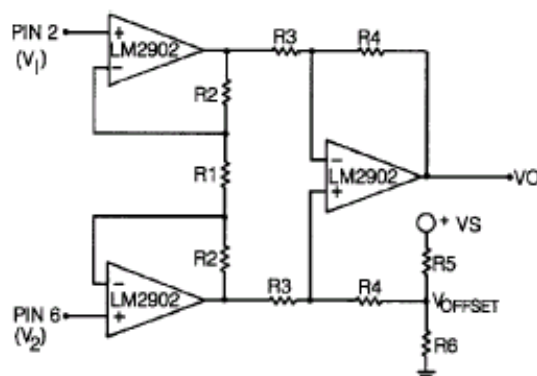

Figure 3
Differential Instrumentation Amplifier Circuit



Equation 1:

$$V_o = \left(\frac{2R_2 + R_1}{R_1} \right) \left(\frac{R_4}{R_3} \right) (V_2 - V_1) + V_{offset}$$

$$\text{where } V_{offset} = V_1 \left(\frac{R_4}{R_1 R_3} \right)$$

Airflow Sensors Microbridge Mass Airflow/Unamplified

AWM2000 Serie:

AWM2000 SERIES ORDER GUIDE (Performance Characteristics @ 10.01 ±0.01 VDC, 25°C)

Catalog Listings	AWM2100V	AWM2150V	AWM2200V	AWM2300V
Flow Range (Full Scale)	±200 sccm	±30 sccm		±1000 sccm
Pressure Range (See Application Note #1)			±4.0" H ₂ O (10 mBar)	
Output Voltage @ Trim Point	30 mV @ 100 sccm	11.8 mV @ 25 sccm	20 mV @ 2" H ₂ O	50 mV @ 650 sccm
Null Voltage Shift, Typ. +25° to -25°C, +25° to 85°C	±0.20 mV	±0.20 mV	±0.20 mV	±0.20 mV
Output Voltage Shift, Max. +25° to -25°C +25° to +85°C	+2.5% Reading -2.5% Reading	+5% Reading -5% Reading	+22% Reading (Note 2) -22% Reading	+5% Reading -5% Reading
Repeatability & Hysteresis, Max.	±0.35% Reading	±0.35% Reading	±0.35% Reading	±1% Reading
	Min.	Typ.	Max.	
Excitation (VDC) (Note 1)	8.0	10±0.01	15	
Power Consumption (mW)	—	30	50	
Null Voltage (mV)	-1.0	0.0	+1.0	
Response Time (msec)	—	1.0	3.0	
Common Mode Pressure (psi)	—	—	25	
Sensor Resistance (kΩ) Pin 2-Pin 1, Pin 6-Pin 1	—	5	—	
Sensor Current (mA) Pin 2-Pin 1, Pin 6-Pin 1	—	—	0.6	
Temperature Range	Operating: -25° to +85°C (-13° to +185°F); Storage: -40° to +90°C (-40° to +194°F)			
Termination	2.54 mm (.100") centers, 0.635 mm (0.025") square			
Weight (grams)	10.8			
Shock Rating	100 g peak (5 drops, 6 axes)			

Notes:

1. Output Voltage is ratiometric to supply voltage.
2. Temperature shifts when sensing differential pressure correlates to the density change of the gas over temperature.
See Application Note 1.
3. Maximum allowable rate of flow change to prevent damage: 5.0 SLPM/1.0 sec.

MOUNTING DIMENSIONS (for reference only)

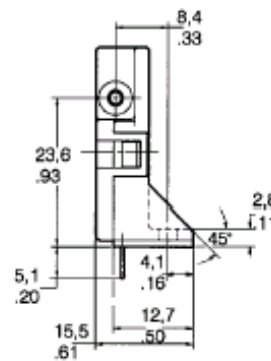
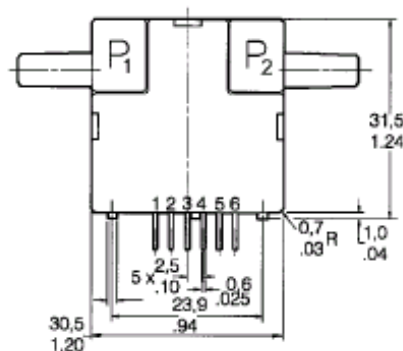
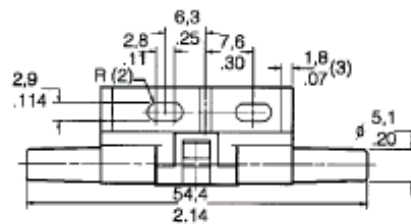

Airflow Sensors

AWM2000 Series

Microbridge Mass Airflow/Unamplified

OUTPUT FLOW VS INTERCHANGEABILITY (Note 1)

Performance Characteristics @ 10.0 ±0.01 VDC, 25°C

AWM2100V				AWM2150V				AWM2200V (Note 2)				AWM2300V			
Press. mBar	Flow sccm	Nom. mV	Tol. ±mV	Press. μBar	Flow sccm	Nom. mV	Tol. ±mV	Flow sccm	Press. " H ₂ O	Nom. mV	Tol. ±mV	Press. mBar	Flow sccm	Nom. mV	Tol. ±mV
0.49	200	44.50	4.25	53	30	14.0	2.5	120	4.00	31.75	3.50	3.4	1000	55.50	3.70
0.35	150	38.75	3.00	36	20	9.5	1.5	90	3.00	26.75	2.50	2.4	800	52.90	3.50
0.21	100	30.00	1.50	17	10	5.0	1.5	60	2.00	20.00	1.20	1.8	650	50.00	2.50
0.09	50	16.50	2.50	9.8	5	2.5	1.0	30	1.00	11.20	1.80	0.83	400	42.50	3.00
0.00	0	0.00	1.00	7.4	4	2.0	1.0	0	0.00	0.00	1.00	0.31	200	29.20	3.20
-0.09	-50	-16.50	4.50	6.2	3	1.5	1.0	-30	-1.00	-11.20	3.00	0	0	0.00	1.00
-0.21	-100	-30.00	5.00	5	2	1.0	1.0	-60	-2.00	-20.00	3.30	-0.31	-200	-28.90	15.00
-0.35	-150	-38.80	7.65	2.5	1	0.5	0.8	-90	-3.00	-26.75	5.30	-0.83	-400	-41.20	26.00
-0.49	-200	-44.50	9.75	0	0	0.0	0.6	-120	-4.00	-31.75	7.00	-1.6	-600	-48.20	29.50
				-9.8	-5	-2.5	2.0					-2.4	-800	-52.20	32.50
				-53	-30	-14.0	5.0					-3.4	-1000	-55.00	36.00

Notes:

- Numbers in BOLD type indicate calibration type, mass flow or differential pressure. Tolerance values apply to calibration type only.
- Differential pressure calibrated devices are not recommended for flow measurement. Use flow calibrated devices for flow measurement.

OUTPUT CURVES

